

外視 / External View

A (1:2.5)

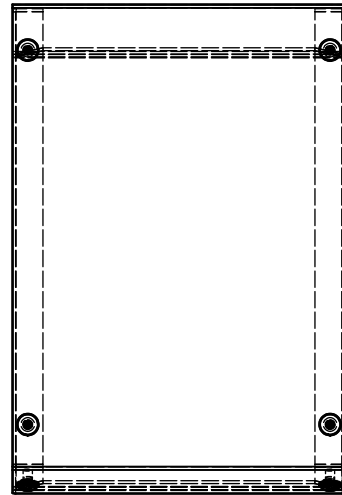

F

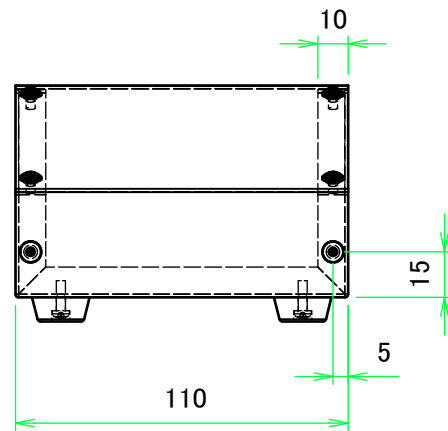

A

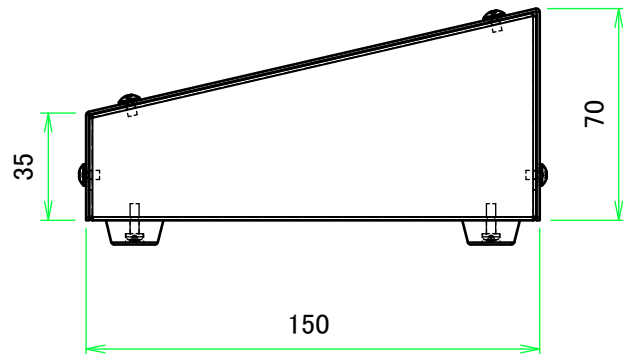

R

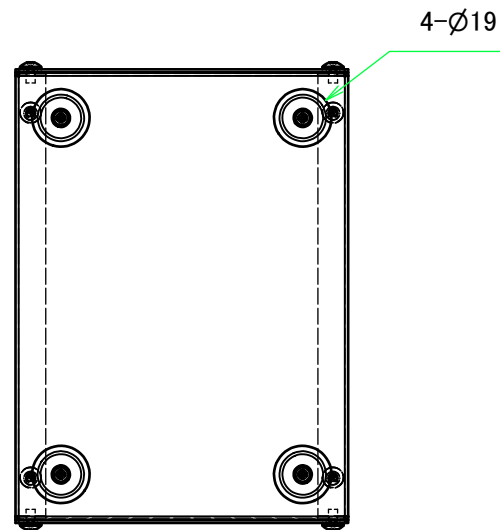
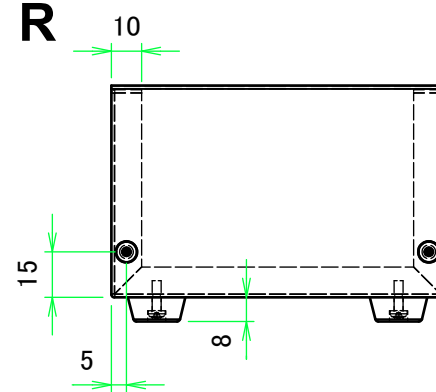

構成内容 / Components				
No.	名称 / Part name	数量 / Pcs	材質 / Material	色・表面処理 / Color・Finish
1	カバー Cover	1	アルミ板 A1100P t1.0 Aluminium A1100P t1.0	シルバーアルマイト Silver anodized
2	シャーシ Base	1	アルミ板 A1100P t1.0 Aluminium A1100P t1.0	ブラック・塗装 Black・Painted
3	ゴム足 / Rubber feet	4	合成ゴム / Rubber	ブラック / Black
4	取付ビス(トラス M3 x 5) Screw(Truss head M3 - 5)	8	真ちゅう Brass	ニッケルメッキ Nickel plated
5	ワッシャー(M3用) Washer(M3)	8	真ちゅう Brass	ニッケルメッキ Nickel plated
6	取付ビス(ナベ M3 x 10) Screw(Pan head M3 - 10)	4	鉄 Steel	三価クロメート Trivalent chromate

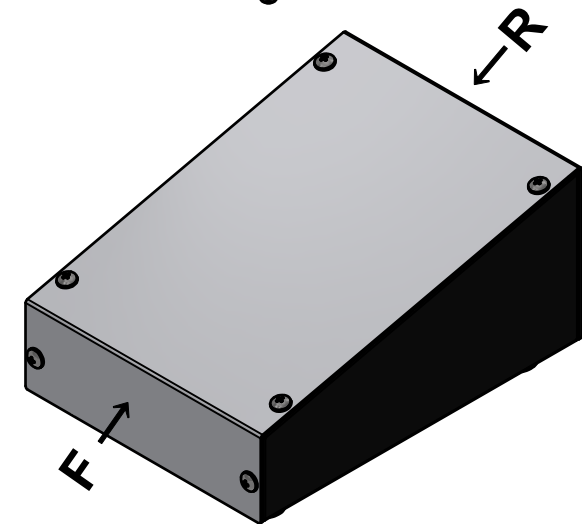
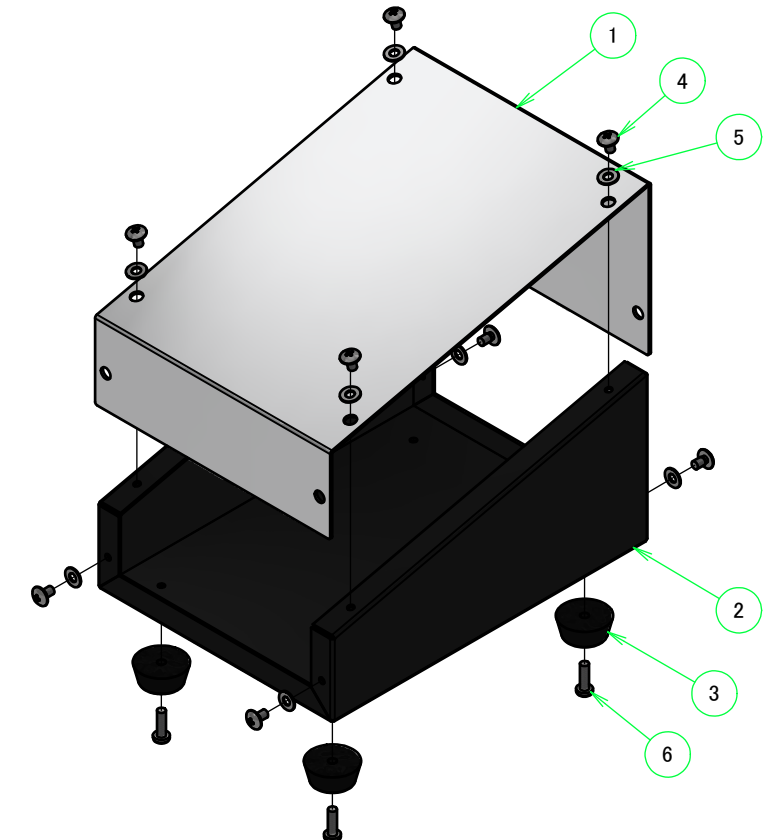

株式会社タカチ電機工業 TAKACHI ELECTRONICS ENCLOSURE CO., LTD.			品名/Title 傾斜ケース SLOPED CASE	尺度/Scale 1:2.5
承認/Approved	検図/Checked	製図/Created	型番/Product number TS11-15	
中根	大江	横田	作成日/Date 2022/05/27	1 / 3

カバー / Cover

B (1:2)

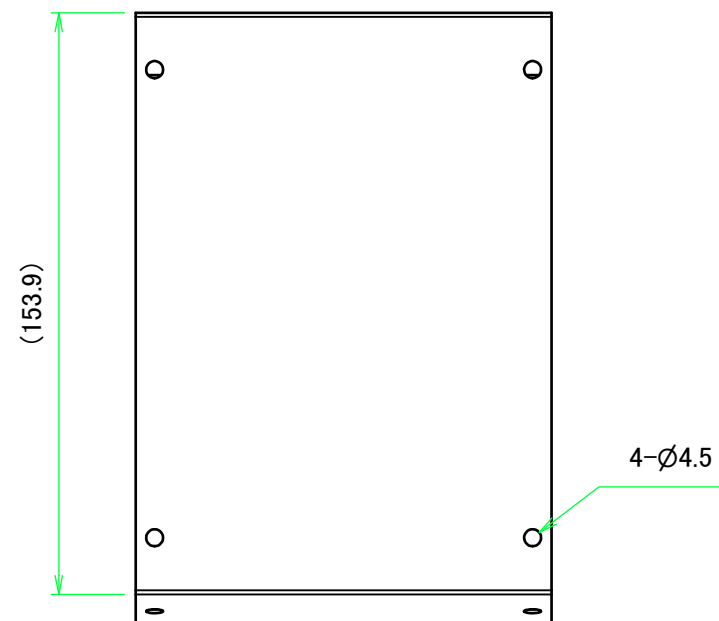

F

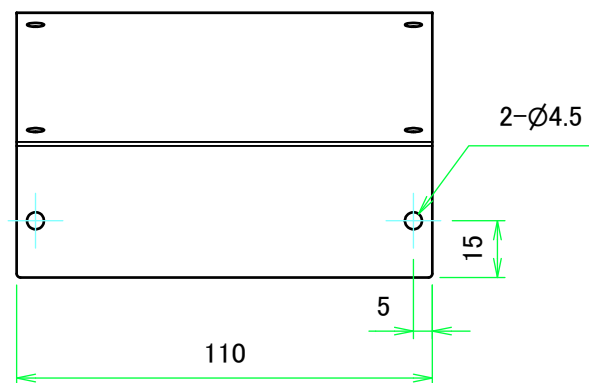

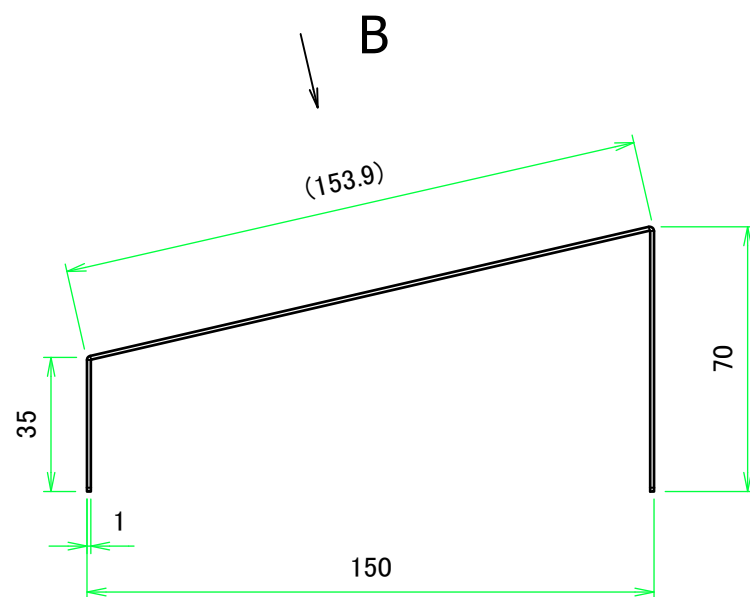

B

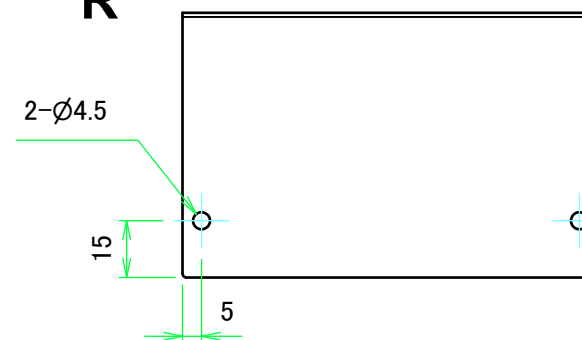

R



 株式会社タカチ電機工業 TAKACHI ELECTRONICS ENCLOSURE CO., LTD.			品名/Title 傾斜ケース SLOPED CASE	 尺度/Scale 1:2
承認/Approved	検図/Checked	製図/Created	型番/Product number TS11-15	
中根	大江	横田	作成日/Date 2022/05/27	2 / 3

シャーシ / Base

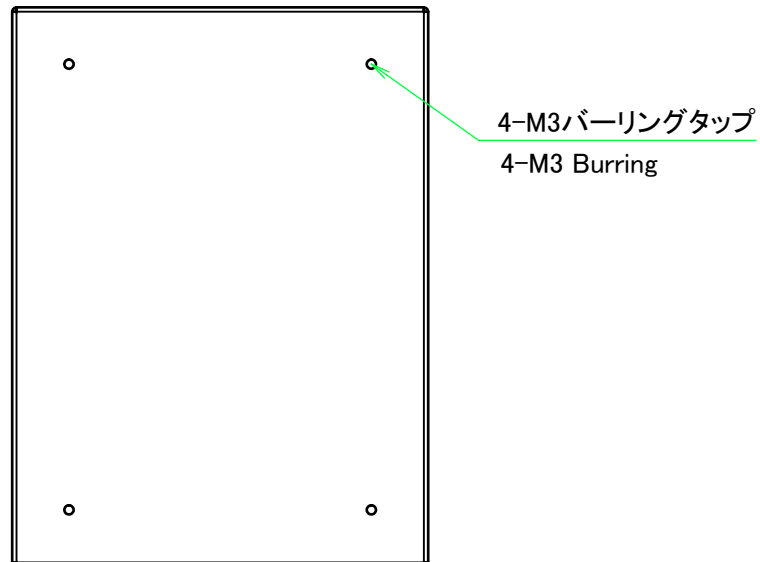
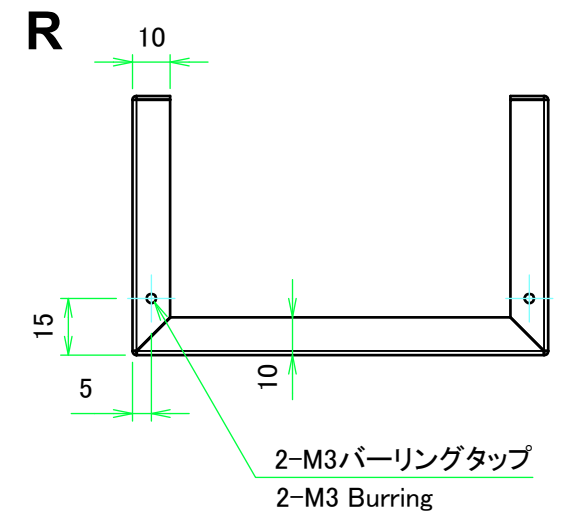
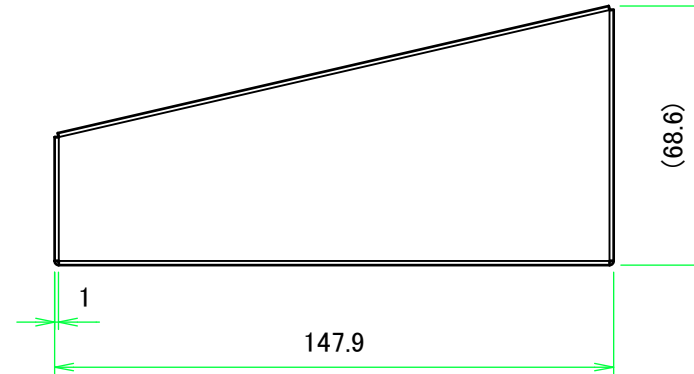
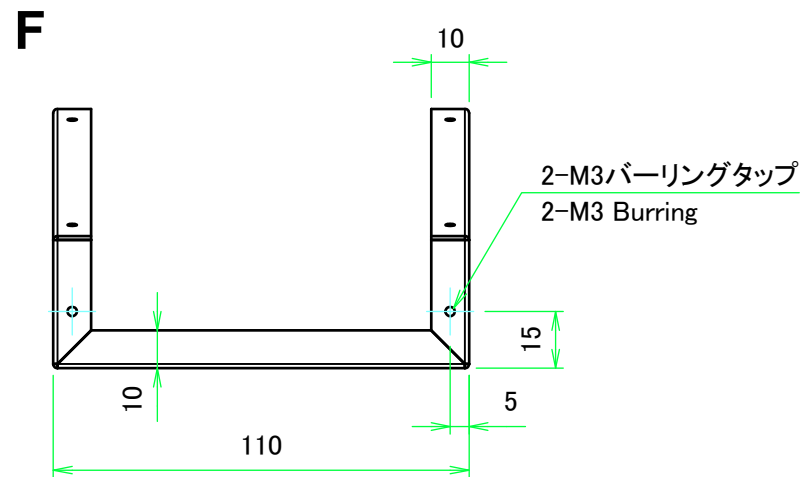
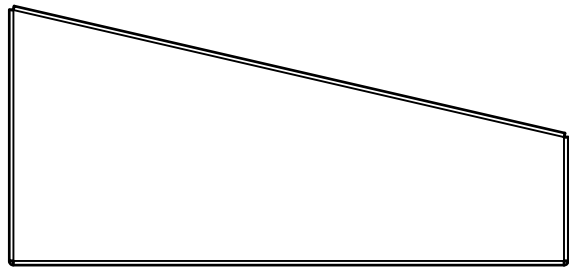
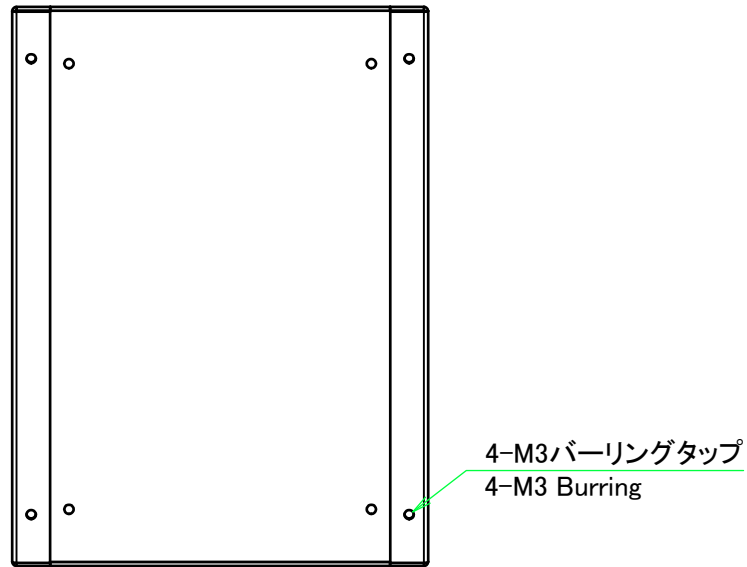

株式会社タカチ電機工業 TAKACHI ELECTRONICS ENCLOSURE CO., LTD.			品名/Title 傾斜ケース SLOPED CASE	尺度/Scale 1:2
承認/Approved	検図/Checked	製図/Created	型番/Product number TS11-15	
中根	大江	横田	作成日/Date 2022/05/27	3 / 3