

構成内容 / Components				
No.	名称 / Part name	数量 / Pcs	材質 / Material	色・表面処理 / Color・Finish
1	カバー Cover	1	ABS樹脂 UL94HB ABS UL94HB	ブラック Black
2	ボディー Bottom base	1	ABS樹脂 UL94HB ABS UL94HB	ブラック Black
3	取付ビス (丸皿タッピング M2.6 x 12) Screw (Self-tapping raised countersunk head M2.6 x 12)	4	鉄 Steel	三価黒クロメート Black trivalent chromate

■テクニカルデータ / Technical Data■

使用温度範囲 / Operating temperature : -10°C ~ +60°C

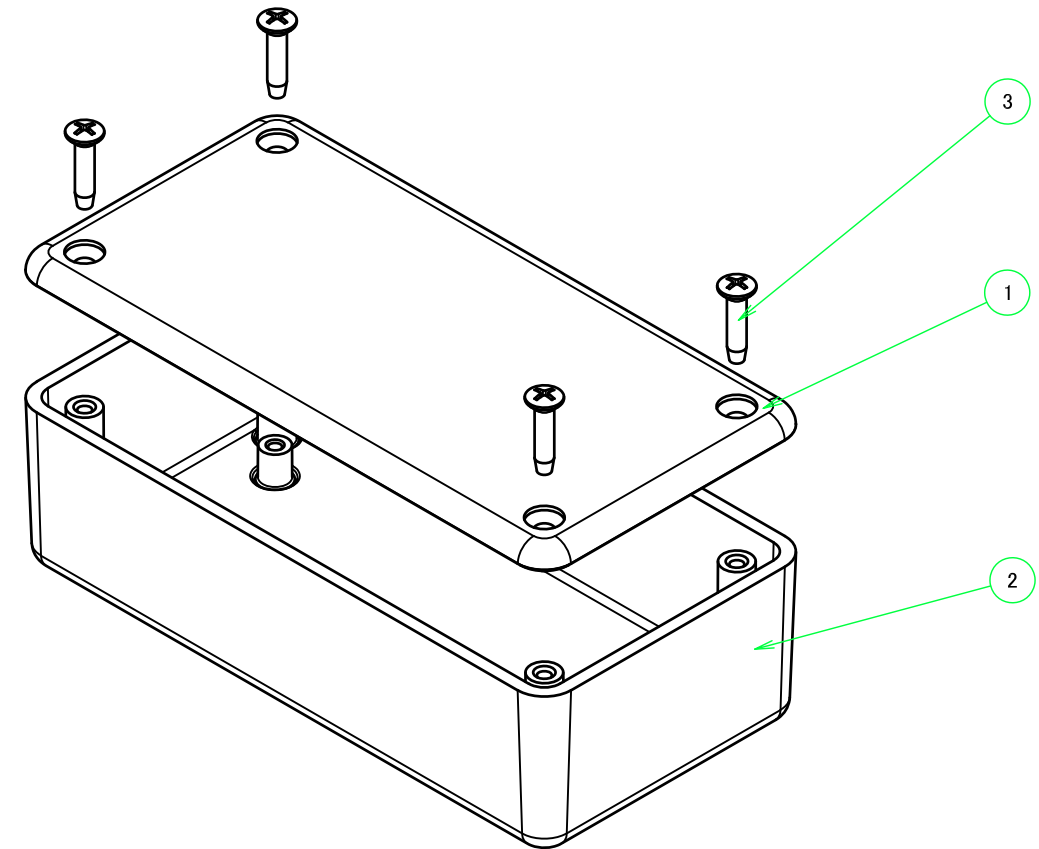

本図面および付帯する部品図の著作権は株式会社タカチ電機工業に帰属します。 / Copyright (C) TAKACHI ELECTRONICS ENCLOSURE CO., LTD. All Rights Reserved.

<b>株式会社タカチ電機工業</b> TAKACHI ELECTRONICS ENCLOSURE CO., LTD.			品名/Title <b>プラスチックケース</b> PLASTIC ENCLOSURE	尺度/Scale 1:1
承認/Approved	検図/Checked	製図/Created	型番/Product number <b>TW5-3-10B</b>	
中根	王	常山	作成日/Date 2023/05/02	1 / 4

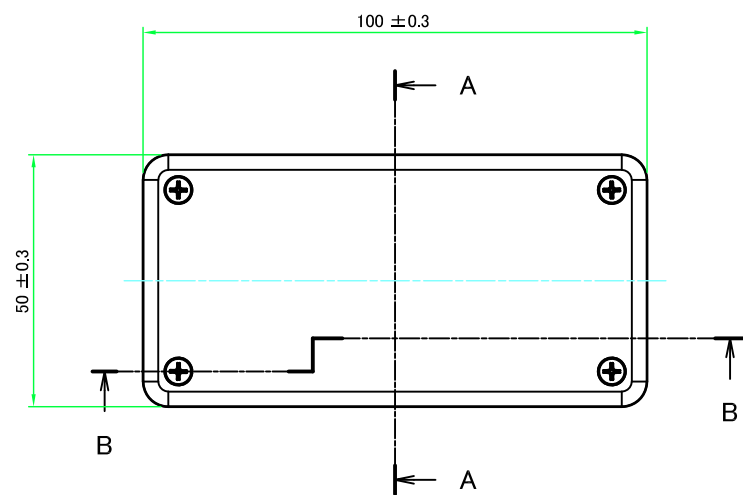
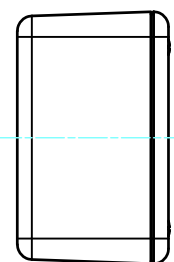
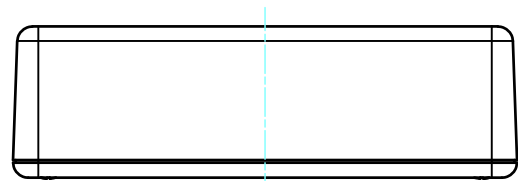

A-A ( 1 : 1.5 )

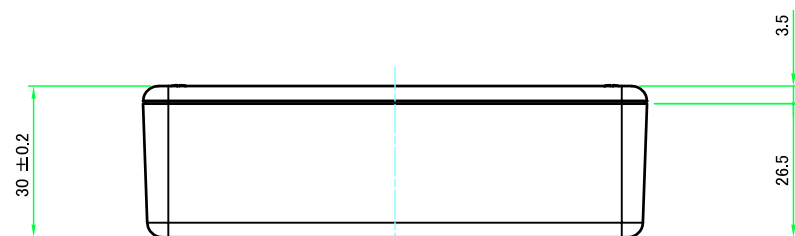
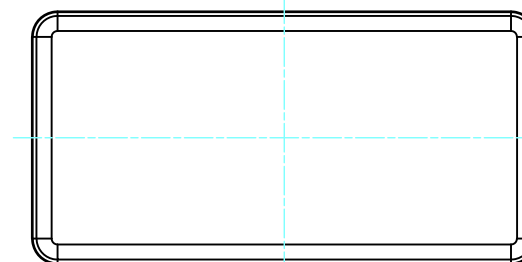
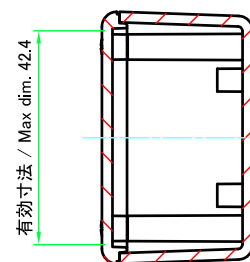
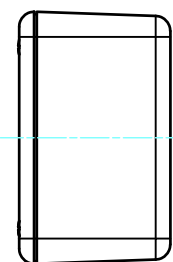

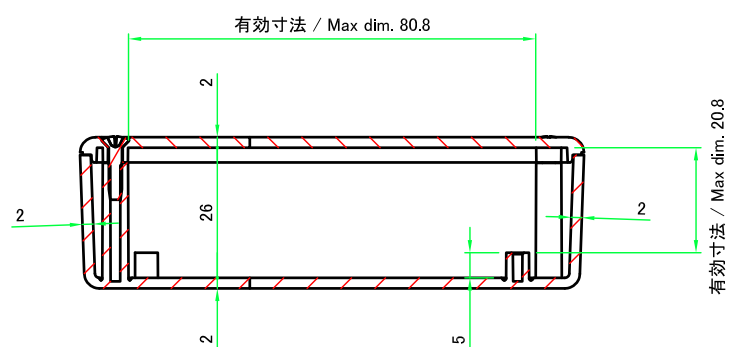

B-B ( 1 : 1.5 )

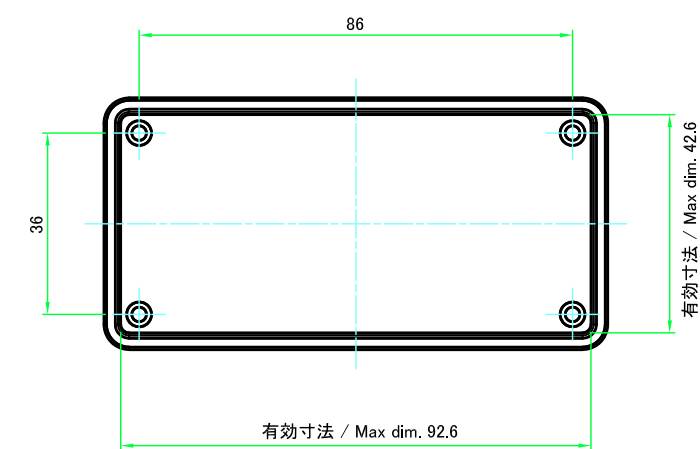
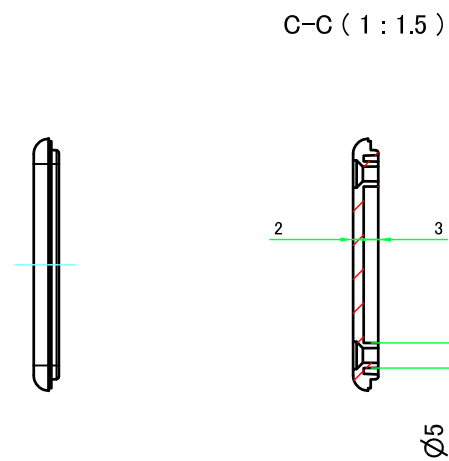
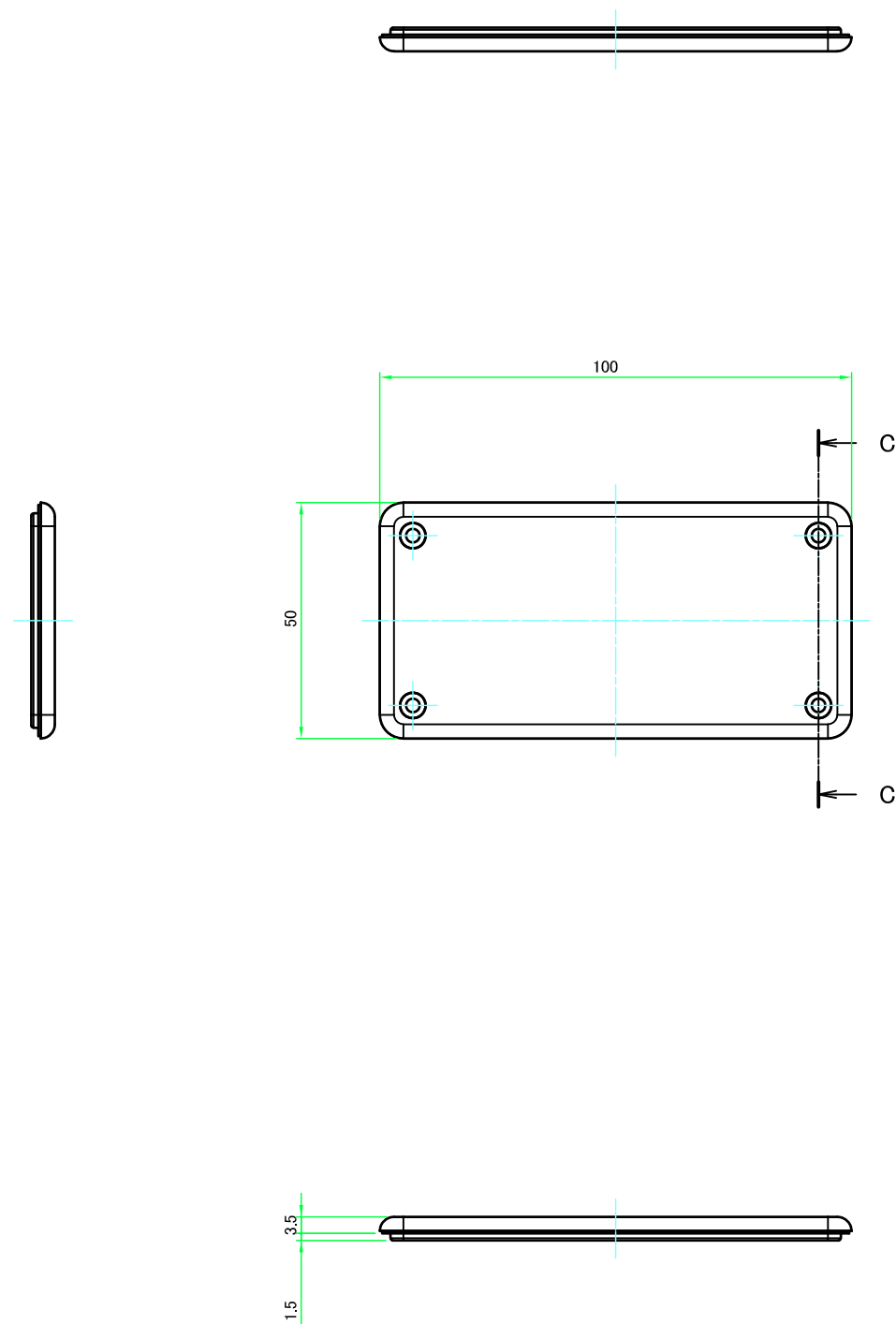

<b>株式会社タカチ電機工業</b> TAKACHI ELECTRONICS ENCLOSURE CO., LTD.			品名/Title <b>プラスチックケース</b> PLASTIC ENCLOSURE	尺度/Scale 1:1.5
承認/Approved	検図/Checked	製図/Created	型番/Product number <b>TW5-3-10B</b>	
中根	王	常山	作成日/Date 2023/05/02	2 / 4

カバー / Cover

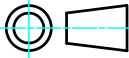

 株式会社タカチ電機工業 TAKACHI ELECTRONICS ENCLOSURE CO., LTD.			品名/Title プラスチックケース PLASTIC ENCLOSURE	 尺度/Scale 1:1.5
承認/Approved	検図/Checked	製図/Created	型番/Product number TW5-3-10B	
中根	王	常山	作成日/Date 2023/05/02	3 / 4

ボディー / Bottom base

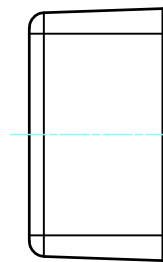
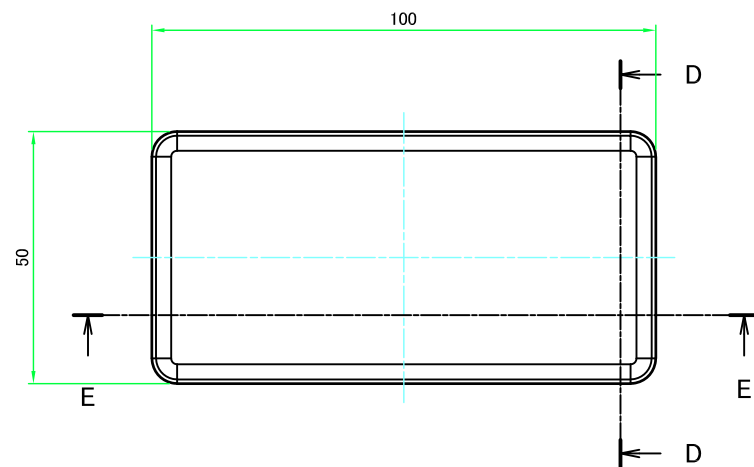
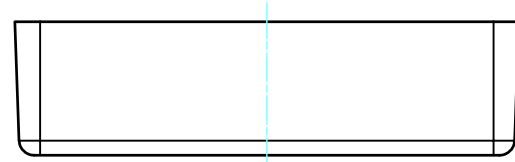

D-D (1:1.5)

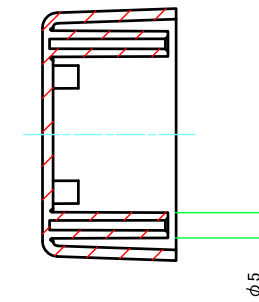

4-M2.3用基板取付ボス  
4-M2.3 Boss

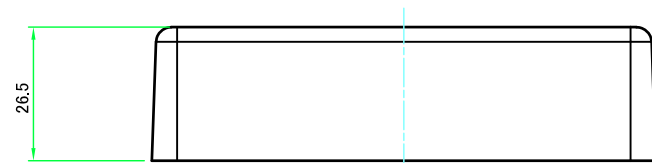
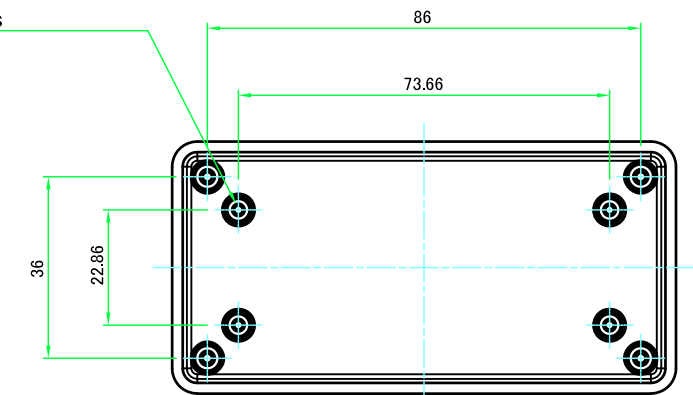

E-E (1:1.5)

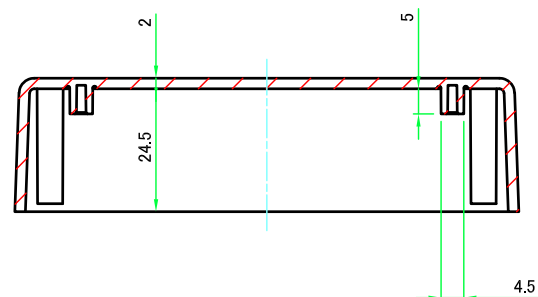

推奨基板形状 \* 販売していません  
Recommended PCB dimension \* NOT SUPPLIED

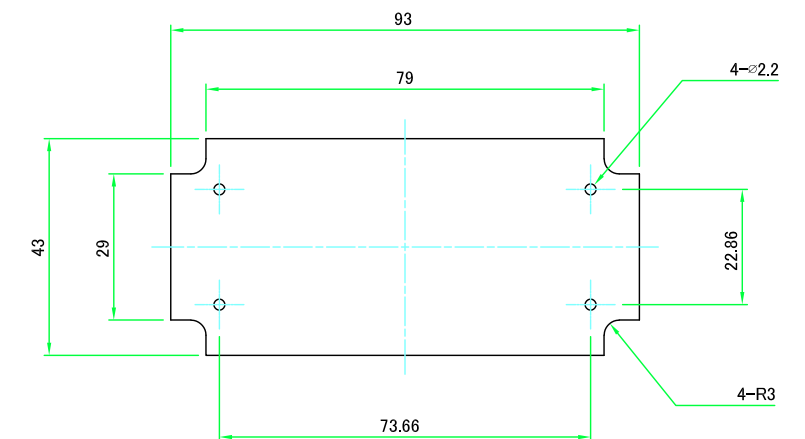

株式会社タカチ電機工業 TAKACHI ELECTRONICS ENCLOSURE CO., LTD.			品名/Title プラスチックケース PLASTIC ENCLOSURE	尺度/Scale 1:1.5
承認/Approved	検図/Checked	製図/Created	型番/Product number TW5-3-10B	
中根	王	常山	作成日/Date 2023/05/02	4 / 4